

# HVC-500



## Characteristic

- Strong control load capacity: rated operational voltage 12VDC~1000VDC, rated operational current 500A
- Safe: Fully sealed with epoxy resin, contact and coil will not be oxidized, product performance is not affected by external environment, no arc outbursts, can be worked in explosive and harmful environment
- Reliable: Adopt DC high voltage non - polarity design, the breaking capacity is higher and more reliable, convenient and reliable installation/wiring
- Energy conservation: Using PWM control technology, effectively control the coil power and action characteristics, more energy saving
- ROHS: All components meet the latest EU RoHS environmental requirements

## Contact parameter

Main contact	Rated operational current Ie	500A
	Rated operational voltage Ue	12 ~ 1000 VDC
	Min. load	1A12VDC
	Main contact type	1SH ( SPST NO DM )
	Nominal resistance of main circuit	MAX 30mV ( @100A )
	Main contact mounting	M8 external thread
	Connecting torque	10 ~ 12 N·m
	Max. switching current ( more than one cycle )	2500A300VDC
Auxiliary contact	Max. current	30VDC 2A; 125VAC 3A
	Min. current	8VDC 100mA
	Contact resistance	< 0.15Ω

## Coil parameter

Rated voltage Us	12/24VDC
Operational voltage Range	9 ~ 36 VDC
Pick up voltage	8 ~ 9 VDC
Release voltage	6 ~ 7 VDC
Coil power	keeping: 3.2W
Inrush current	3.8A ( 0.1s ) ( @12v )
Holding current	0.267A@12V; 0.133A@24V
Close time ( @Us )	≤45ms
Release time ( @Us )	≤10ms
Bounce time ( @Us )	≤5ms

## Electrical characteristics

Dielectric withstand voltage	DC3110V, AC2200V
Insulation resistance	≥1000MΩ@1000VDC
Nominal insulation voltage Ui	1000V

## Environmental characteristics

Shock	Stability test	196m/s <sup>2</sup> ( 20G )
	Strength test	490m/s <sup>2</sup> ( 50G )
Resistance to vibration	10 ~ 2000Hz, 20G	
Operating ambient Temperature	-40°C ~ +85°C	
Operating ambient humidity	5% ~ 85% RH	
IP grade	IP67 ( inner space )	
Altitude	≤4000m	

## Life

Mechanical life	300,000 cycles	
Resistive load life ( L/R ≤ 1ms )	see next page	
Capacitive load life ( RC=1ms, only connected )	500A	30,000 cycles

Note: For capacitive load life, When the contactor is used to control the main circuit of charge and discharge, the pre-charge circuit should be added. If there is no pre-charging path, a transient large current will be generated when the contactor closes, which may cause the contactor to stick

## Other

Weight	≈ 660g; with auxiliary ≈ 665g
The cross-sectional area of an external conductor	≥ 120mm <sup>2</sup>

## Ordering

### Design Code

Rated current	( 500: 500A )
Rated operational voltage	( B: 12VDC~200VDC, Nil: 12VDC~1000VDC )
Rated control supply voltage Us	( 12: 12VDC, 24: 24VDC )
Customer No.	( Customized code when customer has special requirements )

HVC -500 B -12 /XXX

Short overload capacity curve

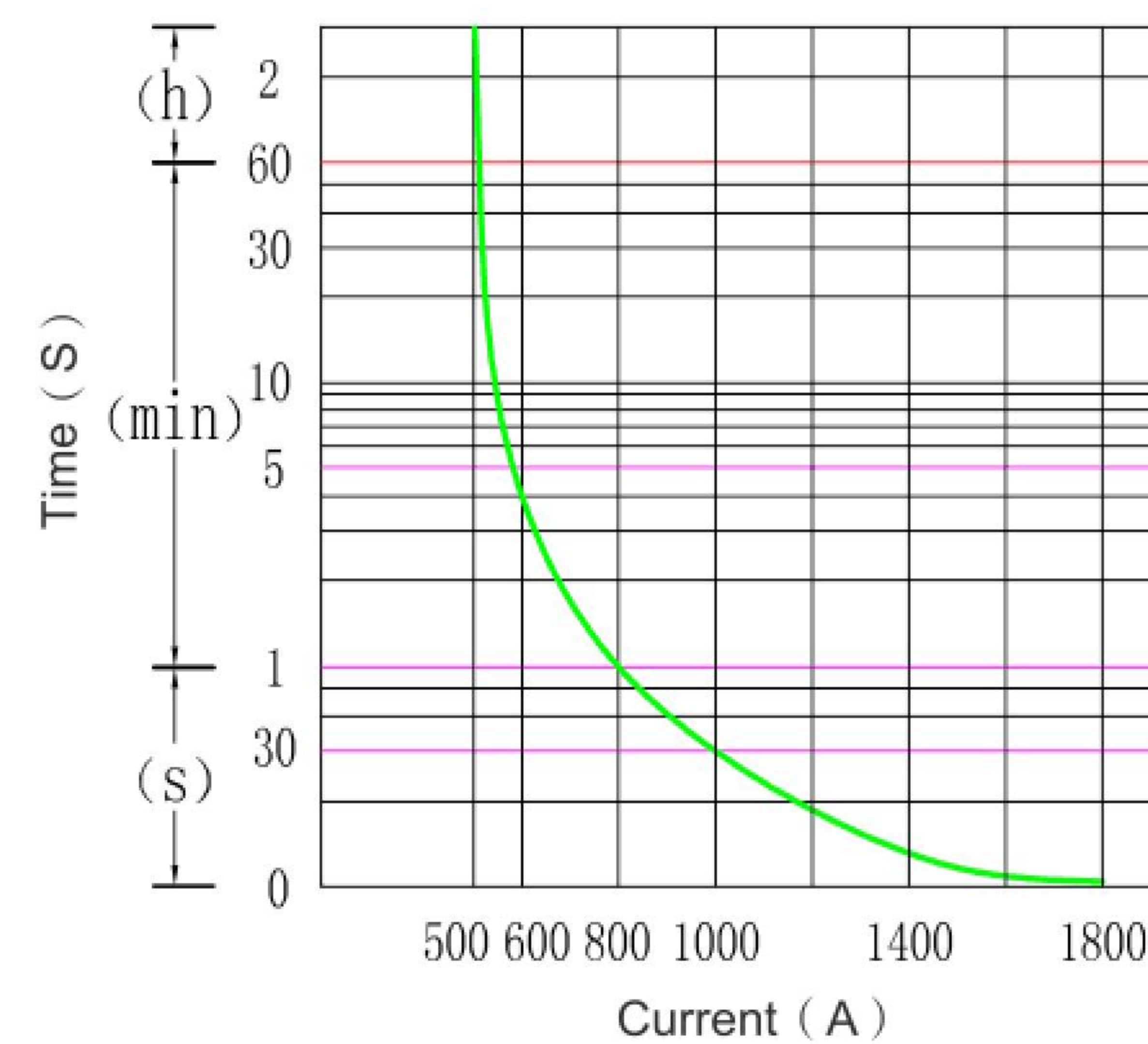

Cut-off life curve of resistive load

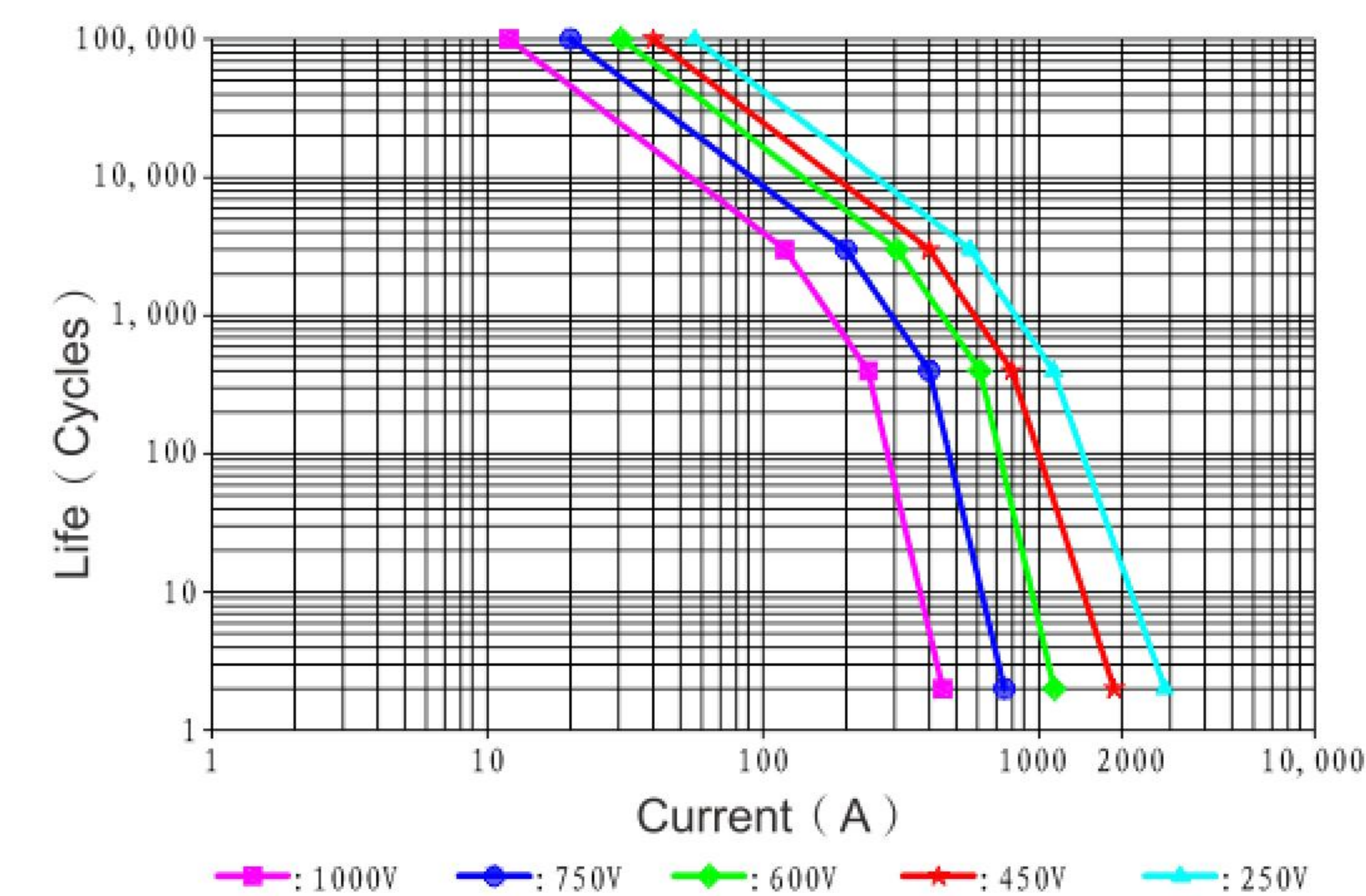

Note: Except for special notes, the ambient temperature of electrical durability test is 23°C, and the on-break ratio is 1s: 9s;

Unit: mm

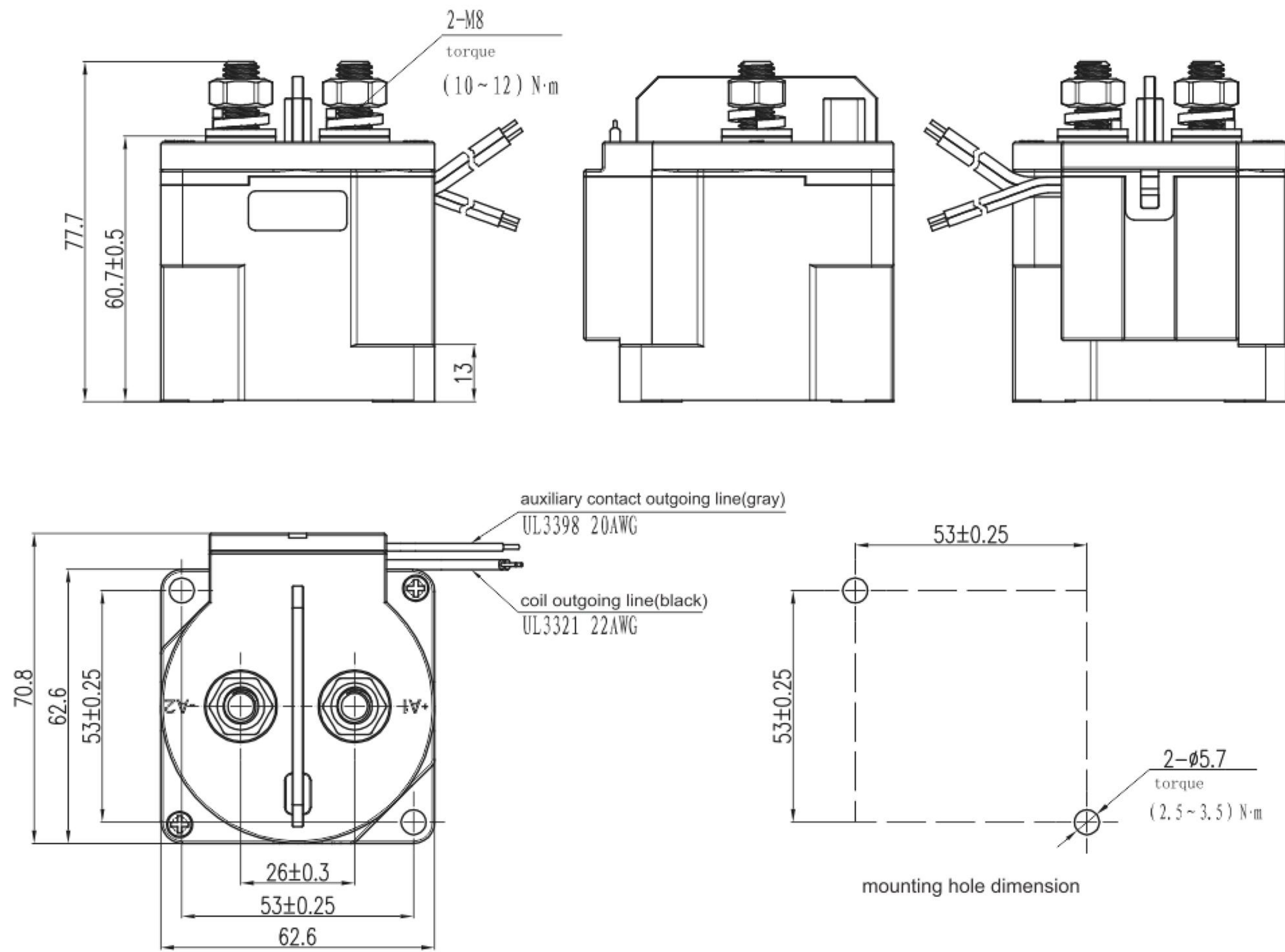

HVC-500 outline dimension

Notes: outgoing line length: 300mm±20mm;  
 product without tolerance, when ≤10mm, tolerance ±0.3mm;  
 when dimension between ( 10~50 ) mm, tolerance ±0.5mm;  
 when dimension ≥50mm, tolerance ±0.8mm.

## Notice

- Using spring washers to prevent loose screws when installing contactors.
- The torque of tightening screws should be within the specified range. Exceeding the maximum torque may lead to product breakage.
- The main contact and control coil lead polarity requirements, can be customized.
- The specification products with energy saving boards are equipped with a reverse surge absorption circuit, so there is no need to use surge protector any more. We suggest that the specification products without energy saving boards should be installed with varistors as surge protector, and the use of diodes should be avoided, because this will reduce the cutting ability of the products.
- Do not use products that have been dropped.
- Avoid placing the product near a strong magnetic field ( near a transformer or magnet ) or near an object with thermal radiation.
- Electrical life  
 This contactor is a high-voltage dc switch. In its final breakdown mode, it may lose its proper cutting function, so it should not be used beyond its switching capacity and life parameters ( please treat this contactor as a product with specified life, and replace it if necessary ) . Once the contactor loses its disconnection ability, it may not work properly, so design the circuit diagram to ensure that the power can be cut off within one second.
- Diffusion life of internal gas  
 This contactor adopts sealed bin contact, and the bin is filled with gas. The diffusion life of the gas is determined by the temperature in the contact bin ( ambient temperature + temperature rise generated by contact electrification ) , so the ambient temperature should be -40°C to +85°C.
- If the coil and contact of the contactor are continuously passed at the rated voltage ( or current ) , the power was cut off and switched on immediately. At this time, as the temperature of the coil increases, the resistance of the coil will increase, which will increase the product's closed voltage, may cause excess of rated closed voltage. In this case, the following measures should be taken: Reduce the load current, limit the duration of continuous power or use coil voltage higher than the rated suction voltage.
- For resistive load, the rated main contact rating shall apply, and for inductive load ( L load ) with  $L/R > 1$  millisecond, an inrush current protection device shall be connected to the inductive load in parallel.
- The drive circuit power of the product coil must be greater than that of the product coil, otherwise the cutting ability of the product will be reduced.
- Be careful not to let sundries and grease on the main lead out end, and the external wiring terminal should be in reliable contact with the main lead out end of the product, or it may cause the lead out end heat.
- For the specification products with energy saving plate, after being connected, the coil will start to switch automatically after about 0.1 seconds. Do not repeatedly turn off at that position, which may damage the contactor.