

# HEV-250



## Characteristic

- Ceramic brazing sealing technology, to achieve the contact part of airtight packaging, no risk of arc leakage, ensure no fire, no burst
- In the airtight package structure, the hydrogen-dominated gas is filled to effectively prevent the oxidation and burning of contact points, and the contact resistance is low and stable
- 250A 85°C long time current carrying capacity
- In response to abnormal conditions, it can break 10 times of over current
- Insulation resistance up to 1000MΩ ( 1000VDC ), dielectric withstand voltage meet IEC60664-1 requirement

## Contact parameter

Contact type	1H
Contact resistance	≤0.3mΩ ( at 20A )
Contact rated current	250A
Max. switching voltage	750VDC
Max. breaking current	2000A ( 450VDC ), more than 1 cycle
Max. switching power	450V: 112.5kW
	750V: 187.5kW
Current carrying capacity	250A: keep
	375A: 10min
	500A: 120s
	1000A: 30s
	2500A: 0.6s

Note: Current carrying capacity data is tested at ambient temperature of 85°C, cross section≥100mm<sup>2</sup>, more detail, please see curve.

## Coil parameter

Rated voltage VDC	Operational voltage VDC	Release voltage VDC	Coil power W
12	≤9	≥1	6
24	≤18	≥2	6

Note: The operational voltage and release voltage are conservative values in the normal temperature.

## Environmental characteristics

Shock	Stability	switch off: 98m/s <sup>2</sup> switch on: 196m/s <sup>2</sup>
	Strength	490m/s <sup>2</sup>
Vibration		10Hz ~ 500Hz 49m/s <sup>2</sup>
Humidity		5% ~ 85%RH
Ambient temperature		-40°C ~ +85°C
IP grade		IP67 ( contact )

## Life

Mechanical endurance	2×10 <sup>5</sup> ops		
	450V	750V	
Electricity endurance	Capacitive load	connect: 2.5×10 <sup>4</sup> ops ( 22.5VDC, τ=1ms ) impact 400A, keep 250A	connect: 2.5×10 <sup>4</sup> ops ( 37.5VDC, τ=1ms ) impact 400A, keep 250A
	Resistive load	switch: 3×10 <sup>3</sup> ops ( 450VDC, 250A )	switch: 500 ops ( 750VDC, 250A )
		switch: 100 ops ( 450VDC, -250A )	switch: 10 ops ( 750VDC, -250A )
		breaking capacity: 1 ops ( 450VDC, 2000A )	breaking capacity: 1 ops ( 450VDC, 2000A )

Note 1: Except for special notes, the ambient temperature of electrical durability test is 23°C and the on-break ratio is 0.6s:5.4s.  
Note 2: When the relay is used to control the main circuit of charge and discharge, the pre-charge circuit should be added. If there is no pre-charging path, a transient large current will be generated when the relay closes, which may cause the relay to stick.

## Electrical characteristics

Insulation resistance	1000MΩ ( 1000VDC )
Dielectric withstand voltage	between contact and coil 4000VAC 1min
	between open contacts 3000VAC 1min
Operate time ( at nomi. volt. )	≤50ms
Release time ( at nomi. volt. )	≤30ms

Note: The data shown above are initial values.

## Other

Terminal	M6 internal thread
Mounting torque at load end	M6 9~11N · m
Relay mounting torque	M5 3~4N · m
Weight	≈570g
Outline dimension	95.0mm×45.0mm×85.0mm

## Ordering

Design Code	HE V -250 /750 -12 -H L 5 W XXX
Application	V: EV
Load current	250:250A
Load voltage	Nil: 450VDC 750: 750VDC
Coil voltage	12: 12VDC 24: 24VDC
Contact type	H: With normally open
Coil input terminal	L: Input wire, B: Input wire +connector
Load input terminal	5: Internal thread
Mounting type	Nil: Vertical mounting W: Horizontal mounting
Customer No.	XXX: Customer requirement Nil: Standard

Note: The customer special requirement express as customer No. after evaluating between each party.

## Outline, coil wiring , installation hole

Unit: mm

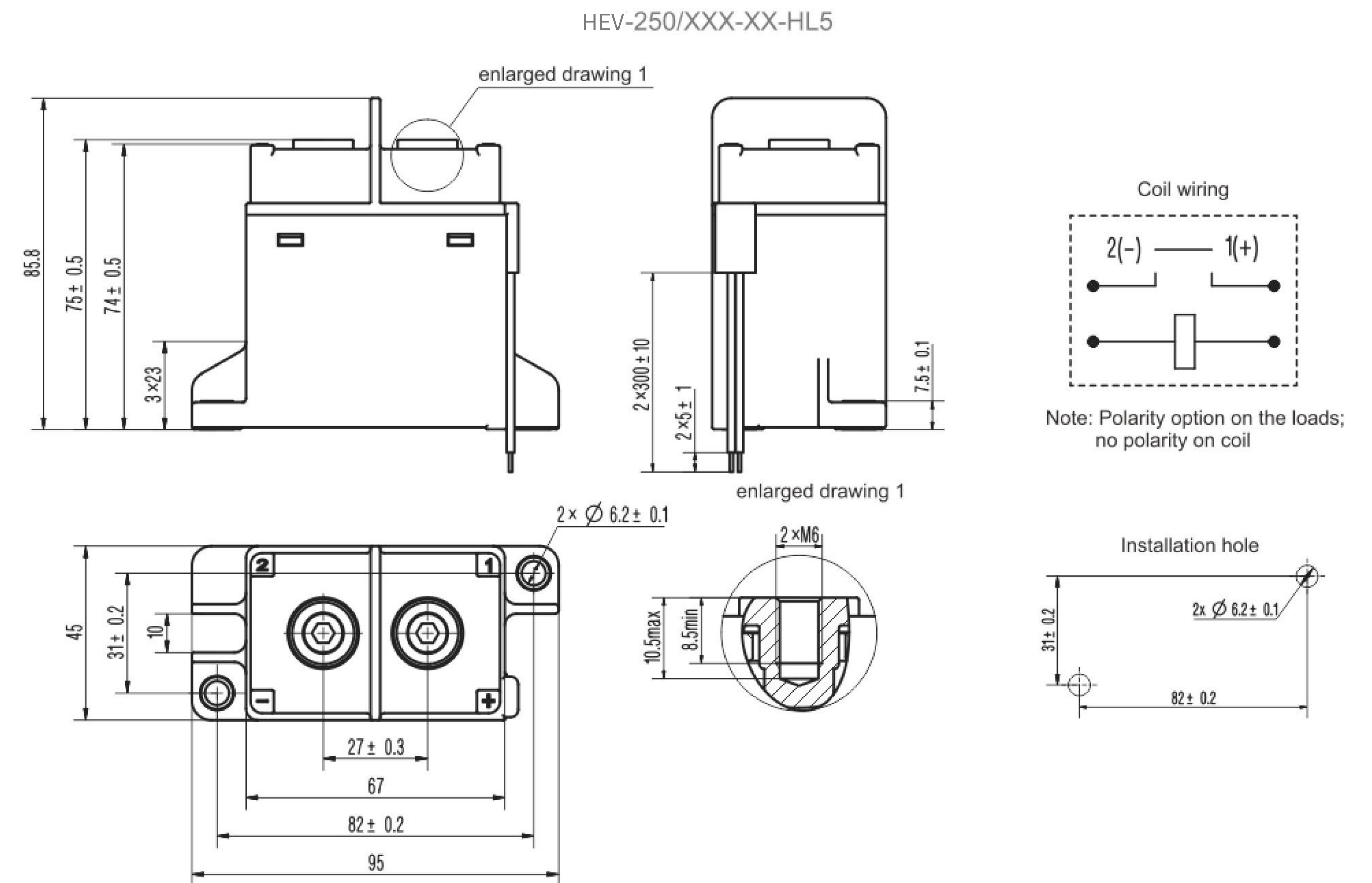

Remark: In case of no tolerance shown in outline dimension: outline dimension≤10mm, tolerance should be±0.3mm; outline dimension is between ( 10 ~ 50 ) mm, tolerance should be ±0.5mm, outline dimension≥50mm, tolerance should be±0.8mm.

Combined bolt Unit: mm

HEV-250

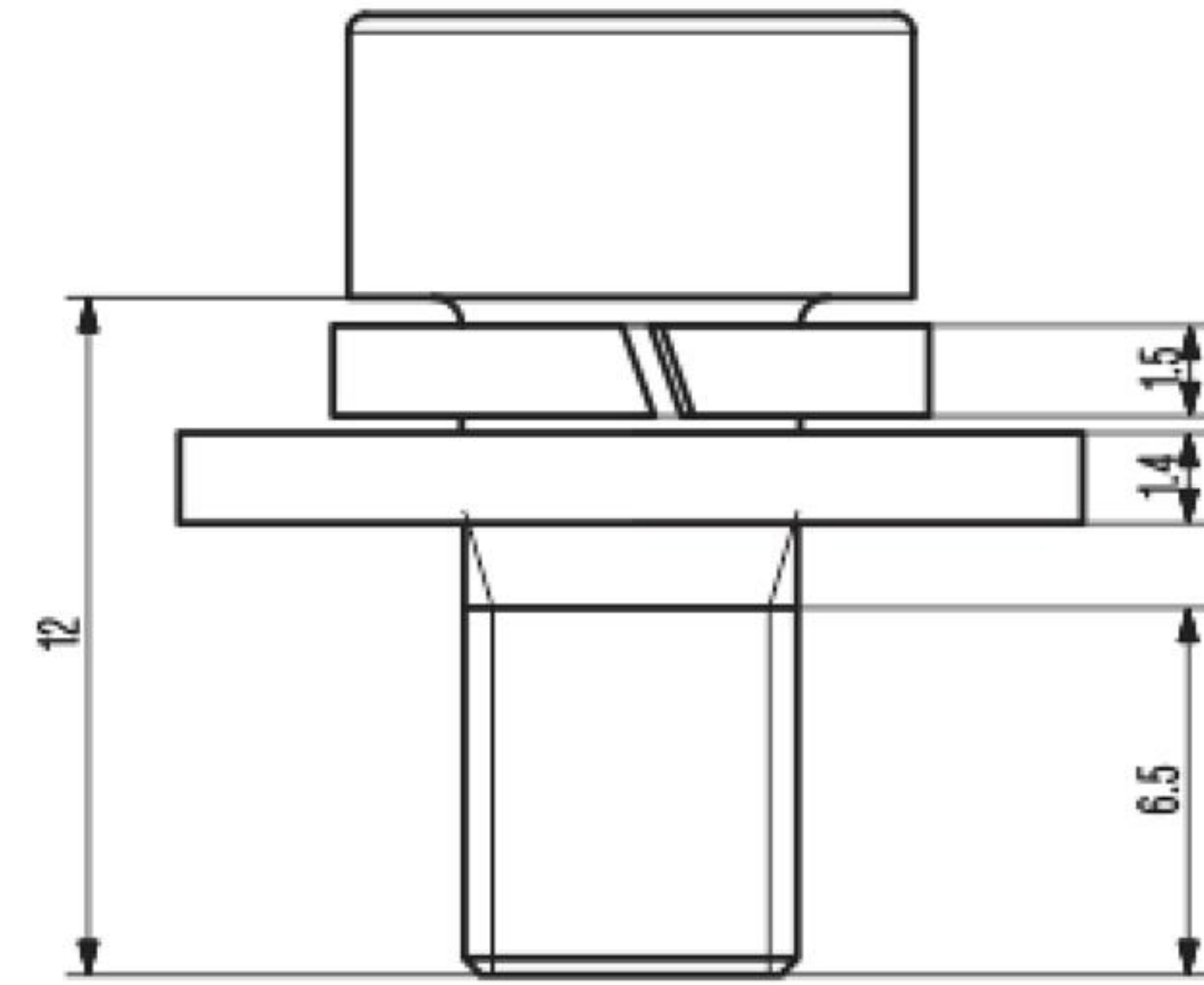

Combined bolt (optional)

Characteristic curve

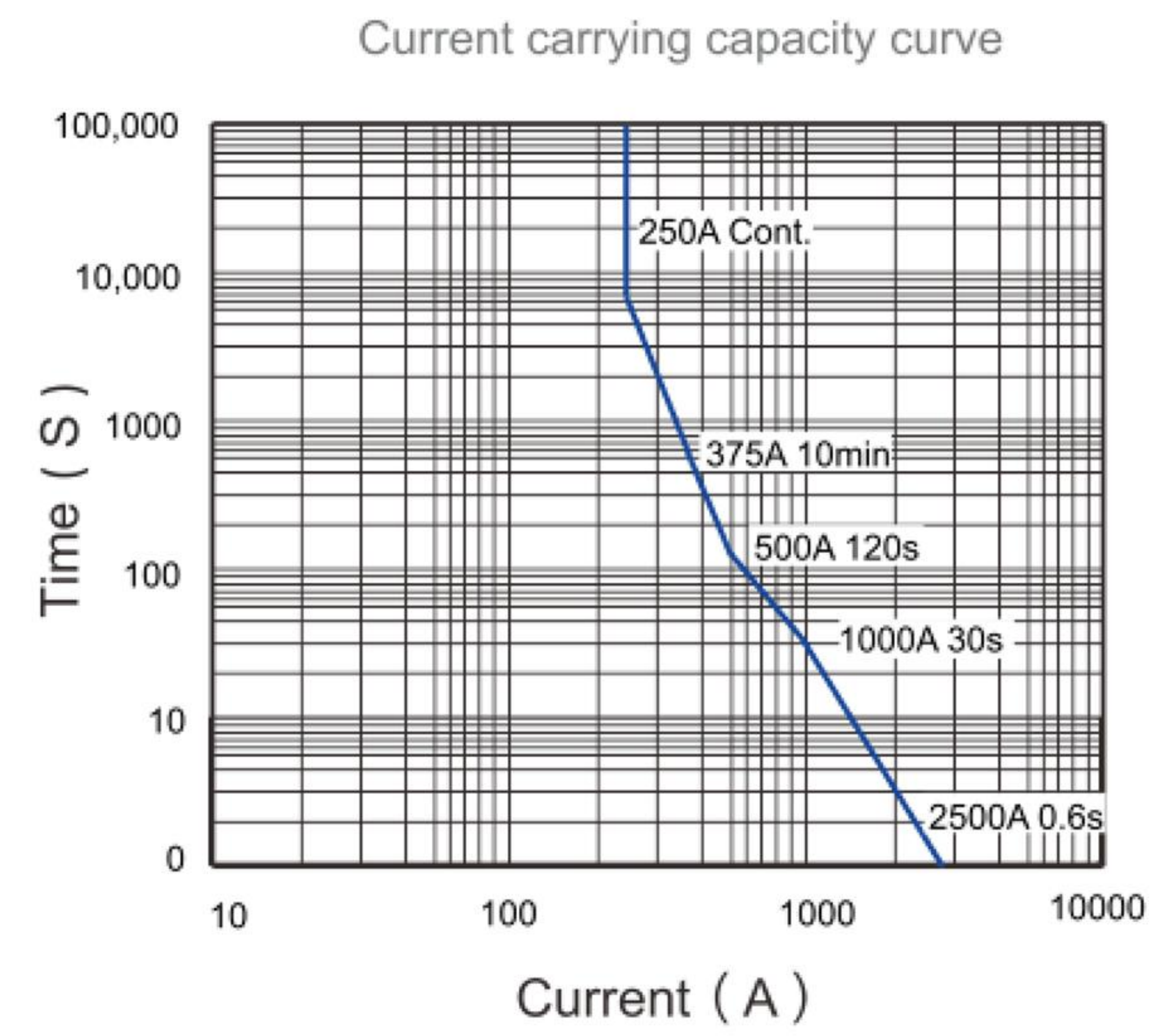

Note: The data above is measured at the environment 85°C, with cross section area of wire ≥ 100mm<sup>2</sup>. The data is only for reference and please do not use it for fuse selection.

Cautions

1. In case of loosening, please use washer when install the relay with M5 screw, and the torque within 3N·m~4N·m, The torque of fixing screw at terminals shall be within 9N·m~11N·m. The torque beyond the range may cause damage.

Installation for terminal with load				Relay installation	
Installation way	Torque	Hole diameter of copper bar	Thickness of copper bar	Installation way	Torque
M6 bolt	9N·m~11N·m	∅6~∅6.5	2mm~3mm	M5 bolt	3N·m~4N·m

2. Please do not adhere foreign materials like oil on the terminals and please use the wire with cross section area 100mm<sup>2</sup> min, otherwise the terminal parts may have abnormal heating.

3. Cautions of relay installation: when use M5 screw, the thickness and strength of the washer needs to be guaranteed or it may deform and burst the cover.