



EHWT100-2Z

EHWT100-2Z

Basic Technical Parameters (at normal conditions)

Electric Parameters			
Contact Arrangement	DPDT-Changeover	Instantaneous maxi (closing) current	7Ie, ≤1s
Rated voltage of contacts (DC)	≤48V	Insulation resistance(MΩ)	≥100
Rated current of contacts (A)	100	Dielectric withstand voltage	1500V,p.f. 1min, no breakdown
Voltage drop on contacts(mV)	≤100	Electric cycles (10 ⁴)	≥2
Coil voltage specification(DC)	12V, 24V, 48V, 72V etc	Mechanical cycles (10 ⁴)	≥30
DC power consumption of coil (W)	≤19	Temperature rise on outgoing terminal	≤65
Pickup voltage(DC)	≤70%Us	Temperature rise of coil(K)	≤85
Release voltage(DC)	≥5%Us; ≤40%Us	Insulation grade of enameled wire	Class B (130°C)
Pickup time(ms)	≤50	Material of contact	AgCuO(10)/Cu
Release time(ms)	≤50	Working duty	Continuous operating duty
Mechanical/Ambient Conditions			
Torque of outgoing terminal on contact M8(N.m)	≥9.0N appropriate	Protection grade	IP50
Coil wiring insert(mm)	≥0.8	Mounting methods	Freely
Working temperature	(-25~+55)°C	Vibration	Sine shock: 2.5g, (5~50) Hz
Mounting altitude	≤2Km	Impact	50g, 11 ms(Half sine)
Conversion Table for Coil Specification(20°C)			
Voltage(V)	Coil resistance(1±10%)Ω	Voltage(V)	Coil resistance(1±10%)Ω
12	7.7	60	189.5
24	30.3	72	272.8
48	121.3	80	336.8

Outline and Mounting Picture

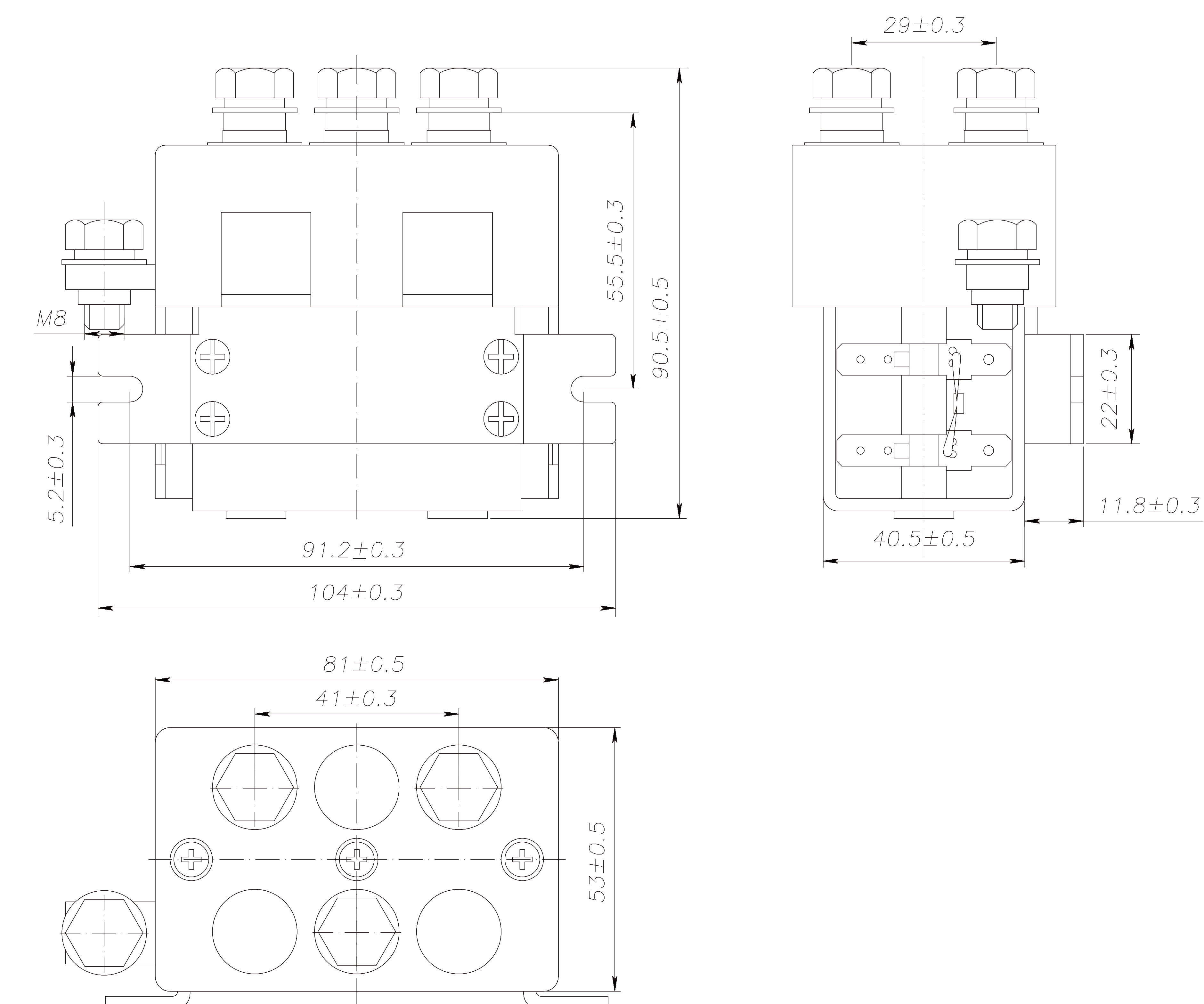

Application

The products are mainly used to control switching on/off of power supply of storage battery car, electric forklift, electric winch, electric car, excavator, air conditioner in vehicle, power source for communication facility.

Ordering Notice

For example: EHWT100-2Z/12V
The DC contactor of main contact is commutation, rated voltage not more than DC48V, current 100A, coil voltage is DC12V

Model and Meanings

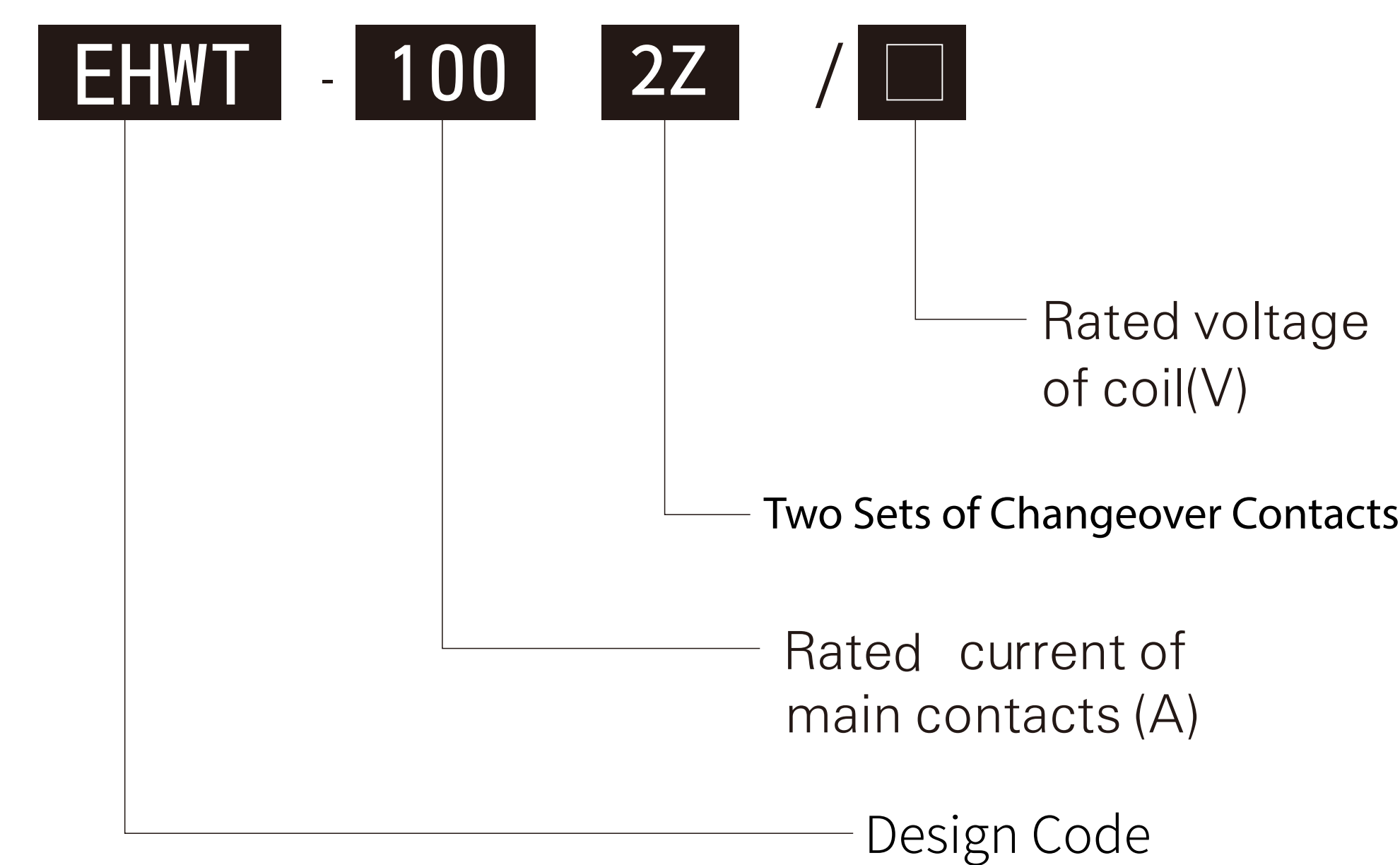

Electric Wiring Diagram

