



EHJ400A

EHJ400A

Basic Technical Parameters (at normal conditions)

		Electric Parameters			
Contact type	SPST-NO	Instantaneous maxi (closing) current	7Ie, ≤ 1s		
Rated voltage of contacts (DC)	≤ 80V	Insulation resistance(MΩ)	≥ 100		
Rated current of contacts (A)	400	Dielectric withstand voltage	1500V,p.f. 1min, no breakdown		
Voltage drop on contacts(mV)	≤ 80 (at 100A)	Electric cycles (10 ⁴)	≥ 2		
Coil voltage specification(DC)	12V, 24V, 48V, 72V etc	Mechanical cycles (10 ⁴)	≥ 30		
DC power consumption of coil (W)	See coil parameter table	Temperature rise on outgoing terminal	≤ 65		
Pickup voltage(DC)	≤ 75%Us	Temperature rise of coil(K)	≤ 85		
Release voltage(DC)	≥ 5%Us; ≤ 40%Us	Insulation grade of enameled wire	Class B (130°C)		
Pickup time(ms)	≤ 30	Material of contact	AgCuO(10)/Cu		
Release time(ms)	≤ 50	Working duty	Continuous operating duty		
		Mechanical/Ambient Conditions			
Torque of outgoing terminal on contact M10(N.m)	≥ 20.5N appropriate	Protection grade	IP50		
Torque of outgoing terminal on coil M4(N.m)	≥ 1.2N appropriate	Mounting methods	Freely		
Working temperature	(-25~+55)°C	Vibration	Sine shock: 2.5g, (5~50) Hz		
Mounting altitude	≤ 2Km	Impact	50g, 11ms(Half sine)		
Conversion Table for Coil Specification(20°C)					
Voltage(V)	Coil resistance(1±10%)Ω		Voltage(V)	Coil resistance(1±10%)Ω	
	Start up	Keep		Start up	Keep
12	1.45	33.0	60	37.5	602.0
24	7.8	80.9	72	33.0	1033.0
48	20.2	398.4	80	49.2	1066.7

Outline and Mounting Picture

Application

The products are mainly used to control switching on/off of power supply of storage battery car, electric forklift, electric winch, electric car, excavator, air conditioner in vehicle, power source for communication facility.

Ordering Notice

For example: EHJ400A/12V
The DC contactor of main contact is one NO, rated voltage not more than DC 80V, current 400A, coil voltage is DC12V

Model and Meanings

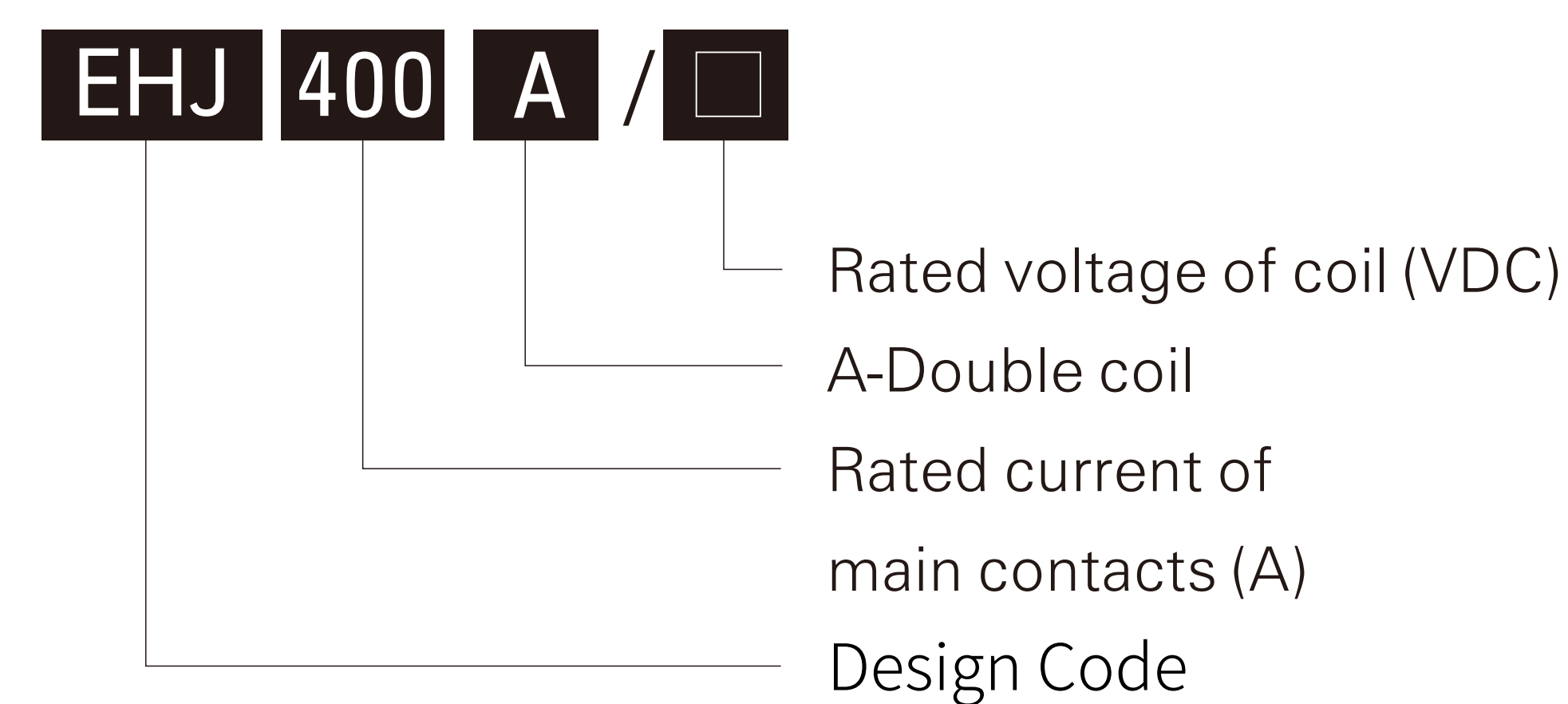

Electric Wiring Diagram

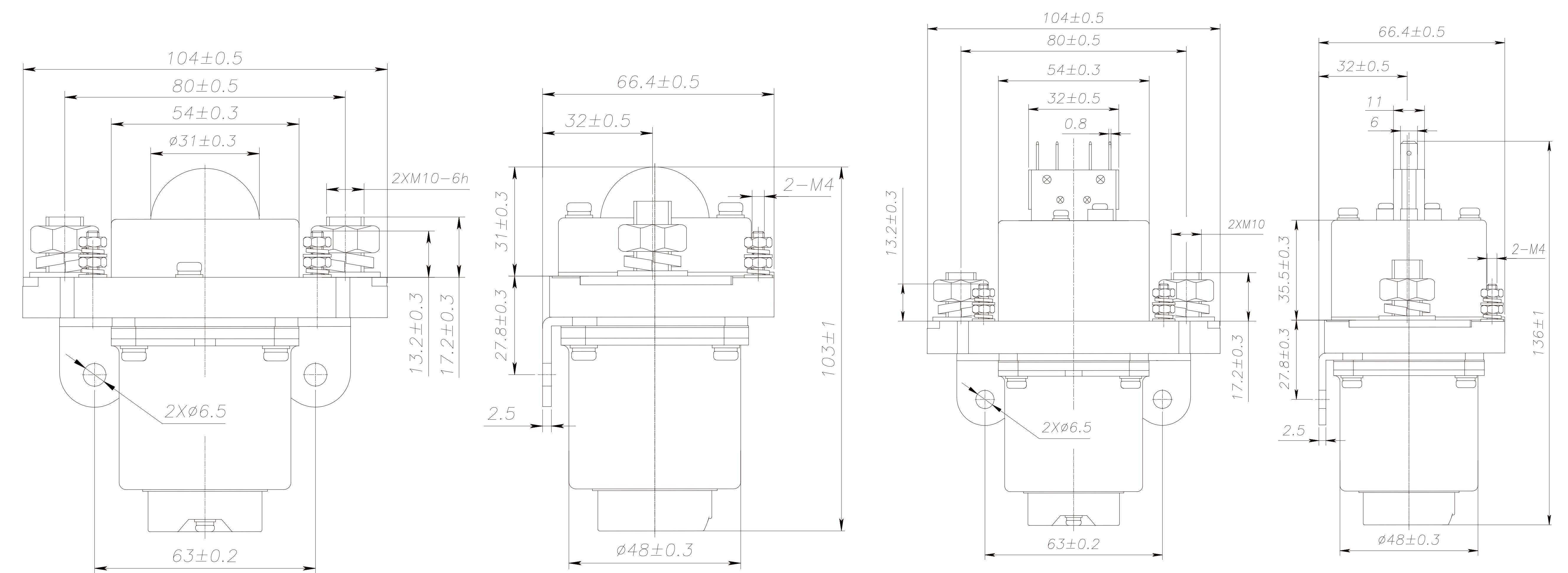
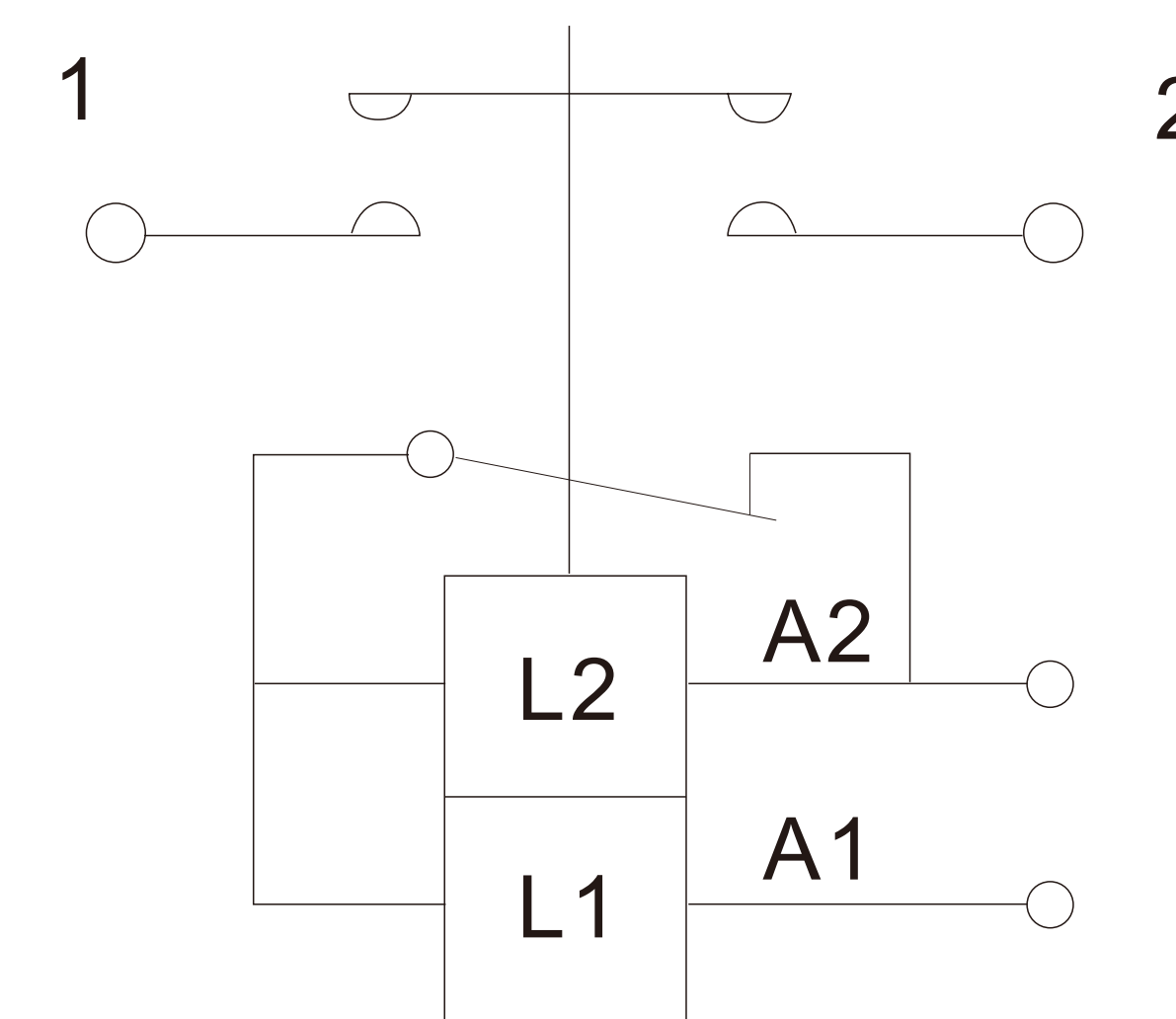

EHJ400A

EHJ400AS